

# Panel Mounted Heat Exchangers by Dantherm, Inc.



## PRODUCT INFORMATION MANUAL

## **Contents**

1. GENERAL SAFETY & WARNING INSTRUCTIONS	3
2. UNPACKING, HANDLING & INITIAL INSPECTION	3
3. MODEL IDENTIFICATION	4
4. OPTIONS	4
5. PRODUCT DRAWINGS	5
6. MOUNTING OF UNIT TO ENCLOSURE & OPERATION	9
7. DESIGN DATA: GENERAL PERFORMANCE	10
8. MAINTENANCE	10
9. WARRANTY	13
10. RETURN MATERIAL AUTHORIZATION PROCEDURE	14

## **1. GENERAL SAFETY & WARNING INSTRUCTIONS**

- Certain parts of electrical systems are inevitably live or have high operating temperatures. Observe caution at all times.
- Failure to observe these conditions and installation instructions can cause injury and damage.
- The system is to be installed and maintained only by trained and qualified personnel.
- Do not apply power until all ground connections have been made.
- The unit is fitted with pressed and folded metal parts, which could have sheared metal edges. Be cautious handling the unit, especially when working in poorly accessible places.
- Check that no tools, test equipment, torches etc. have been left in or on the equipment on completion of work.
- Ensure the cover(s) and all mounting hardware is firmly secured before leaving installation.
- All cable and connectors must conform to UL standards.
- The heat exchanger is UL recognized and tested to UL1995. It will comply where necessary with the safety requirements as defined in UL1995.

## **2. UNPACKING, HANDLING & INITIAL INSPECTION**

The heat exchanger should be inspected on initial delivery and any damage to packaging noted. The unit should be maintained in the upright position at all times. Special consideration should be given to correctness of external packing damage or abrasion, loose components and surface marks. Any damage should be added to the freight bill and immediately notify the freight company for filing a freight claim. All packaging materials should be retained for inspection.

***Do not attempt to operate the unit if it appears to be damaged.***

### 3. MODEL IDENTIFICATION

#### 3.1. Model numbering format

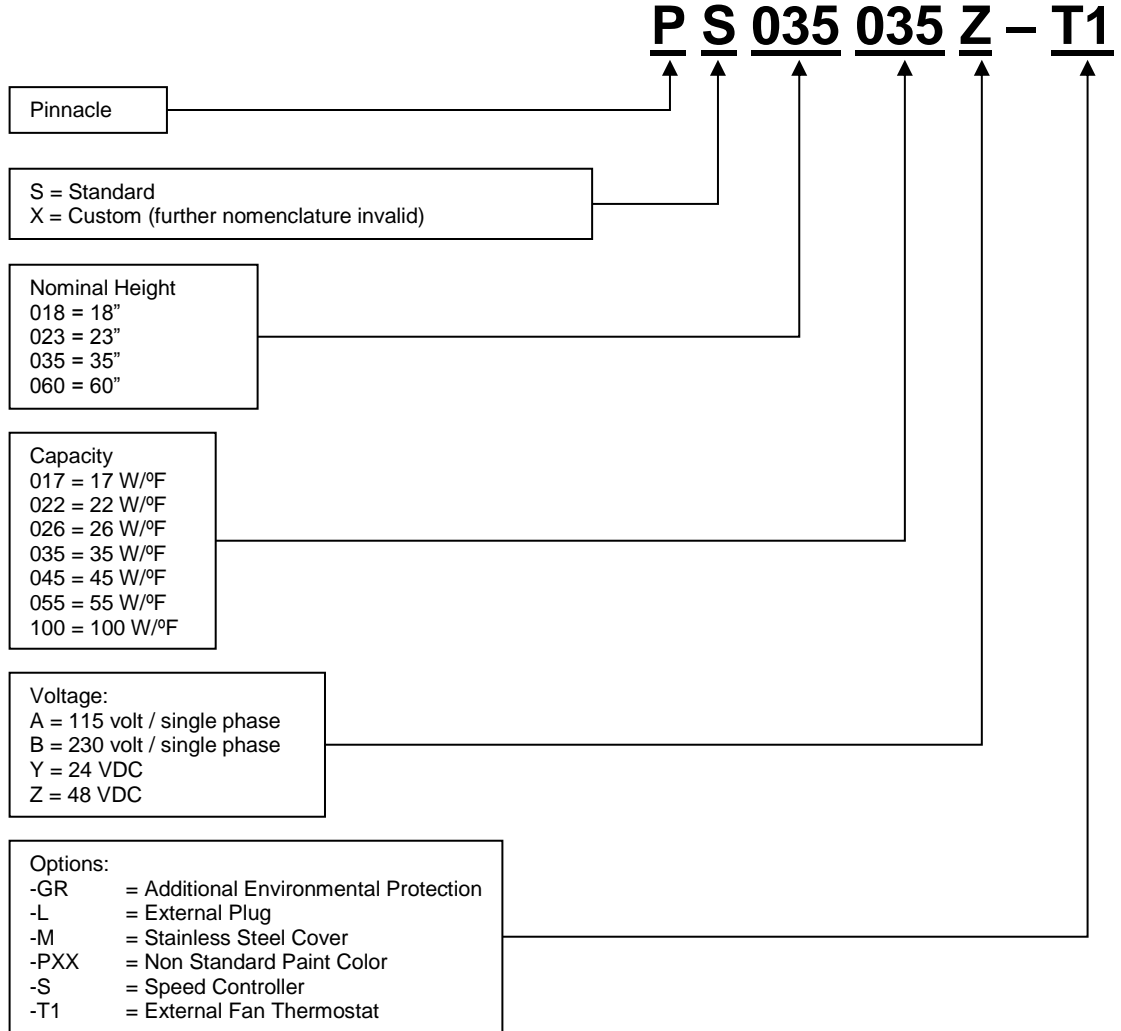

### 4. OPTIONS

#### 4.1. Speed Control (-S)

The controller is designed to slow down the speed of the internal and external fans at lower temperatures to reduce noise and energy consumption. It will also supply either a normally closed (NC) or normally open (NO) alarm signal for fan fault, sensor fault, or high temperature.

#### 4.2. Thermostat Control (-T1)

A snap disc thermostat controls the operation of the external loop fan. A temperature rise above 80F will cause the fan to be turned on, a temperature decrease below 60F will cause the fan to be turned off; between the range of 60F-80F the fan will be operating based on the pervious environmental condition experienced.

## 5. PRODUCT DRAWINGS

### 5.1. General configuration

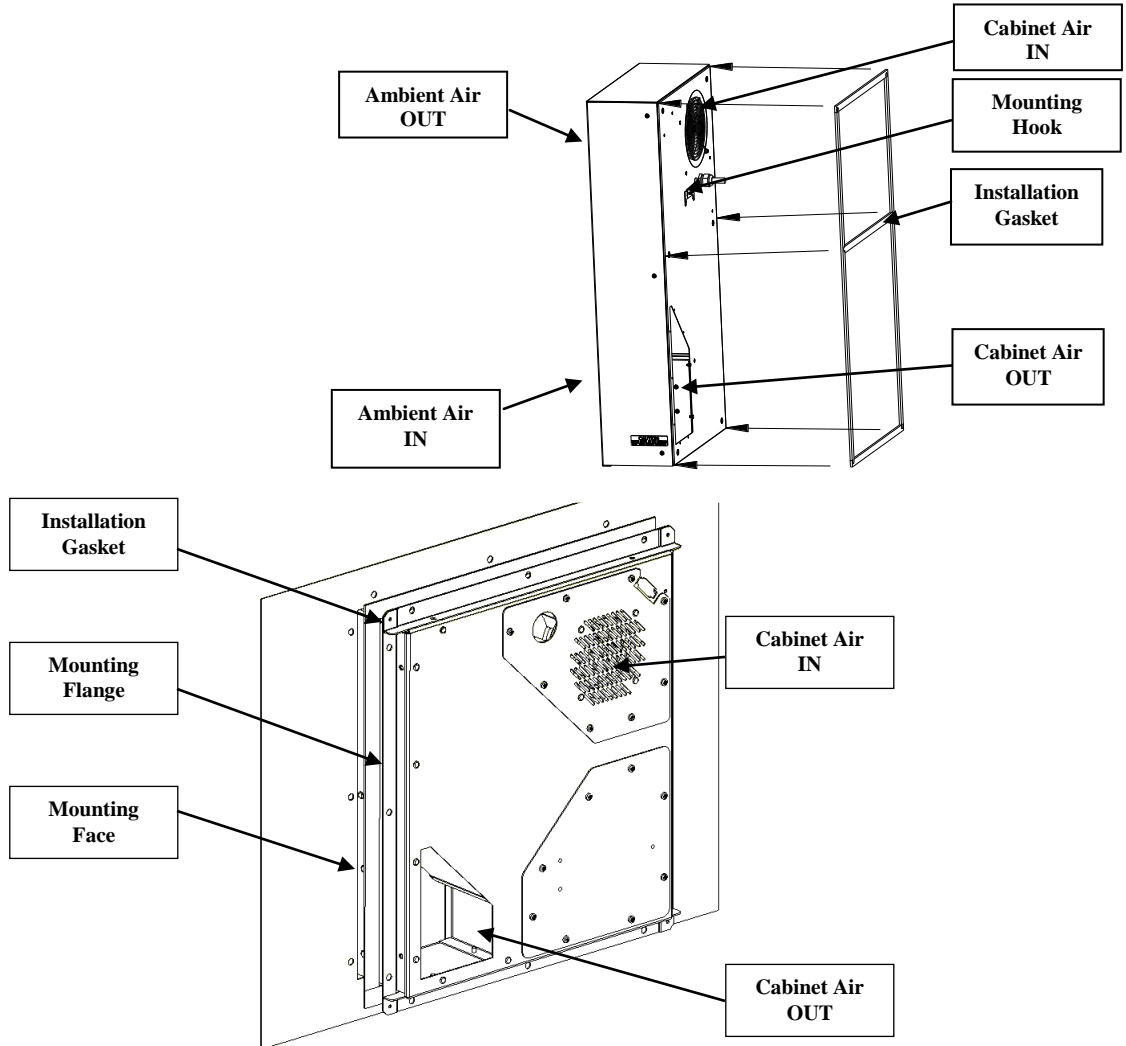

## 5.2. Cut Out and Mounting Diagrams

### 5.2.1. PS018XXX-XX series

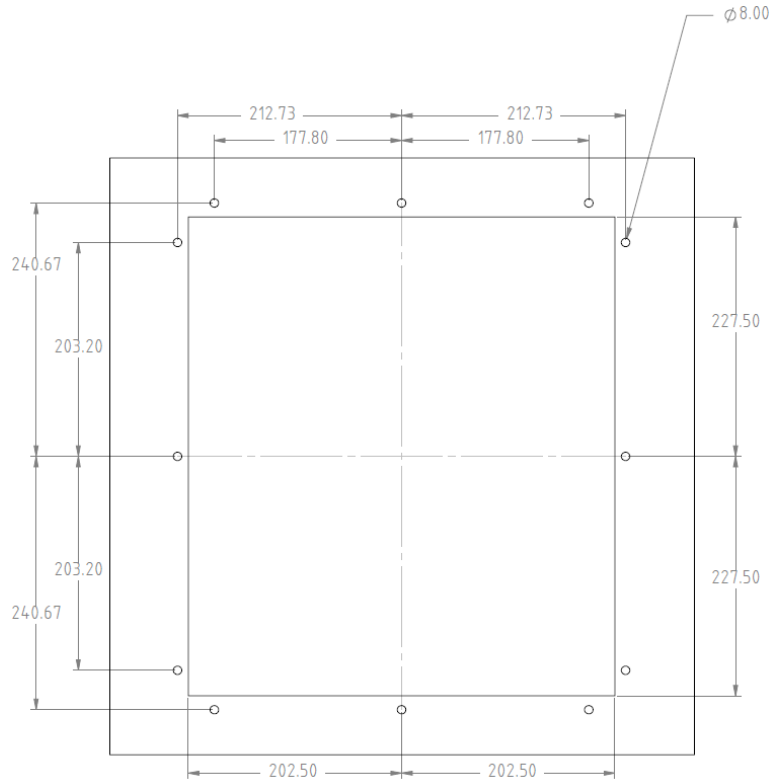

### 5.2.2. Cut Out & Mounting Information for older PS023011/017/022-XX series (prior to 2008)

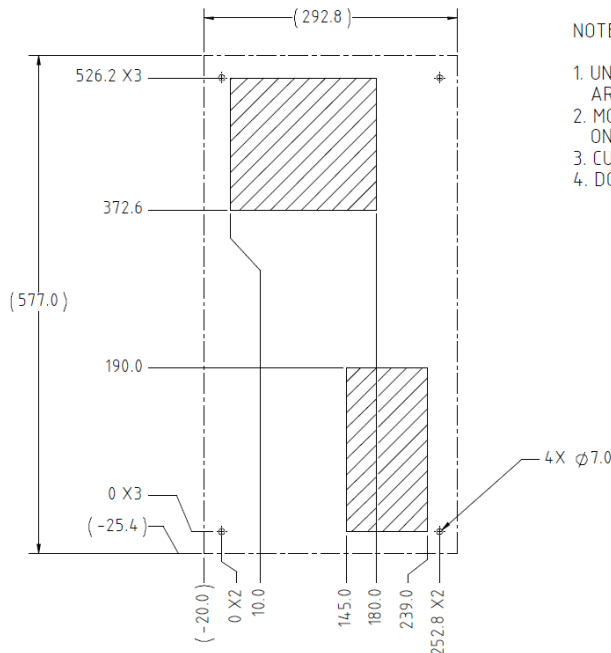

NOTES:

1. UNLESS OTHERWISE SPECIFIED, ALL DIMENSIONS ARE IN MILLIMETERS
2. MOUNTING TEMPLATE IS DISPLAYED AS MARKED ON MOUNTING SURFACE.
3. CUT AWAY HATCHED AREAS.
4. DO NOT SCALE DRAWING.

**5.2.3. Cut Out & Mounting Information PS023011/017/022-XX series  
(2008 –on)**

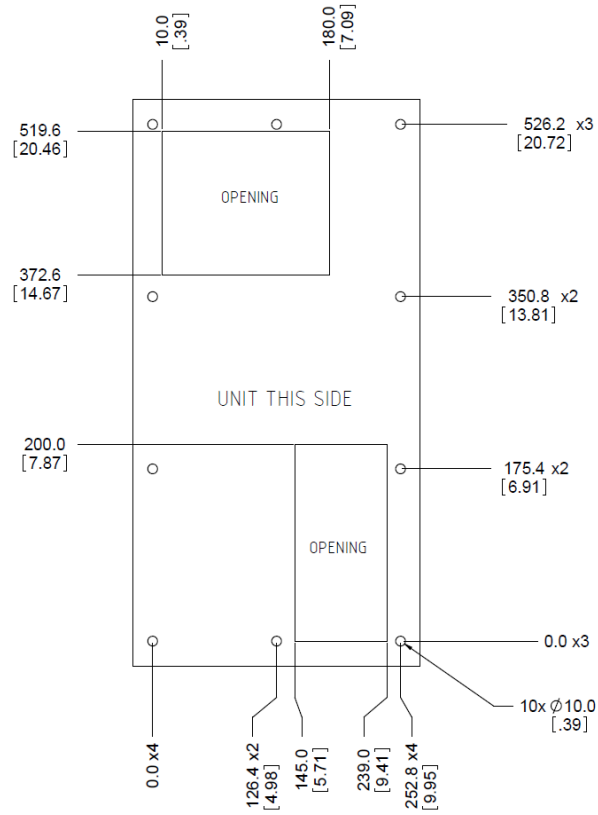

**5.2.4. Cut Out & Mounting Information PS023026-XX series**

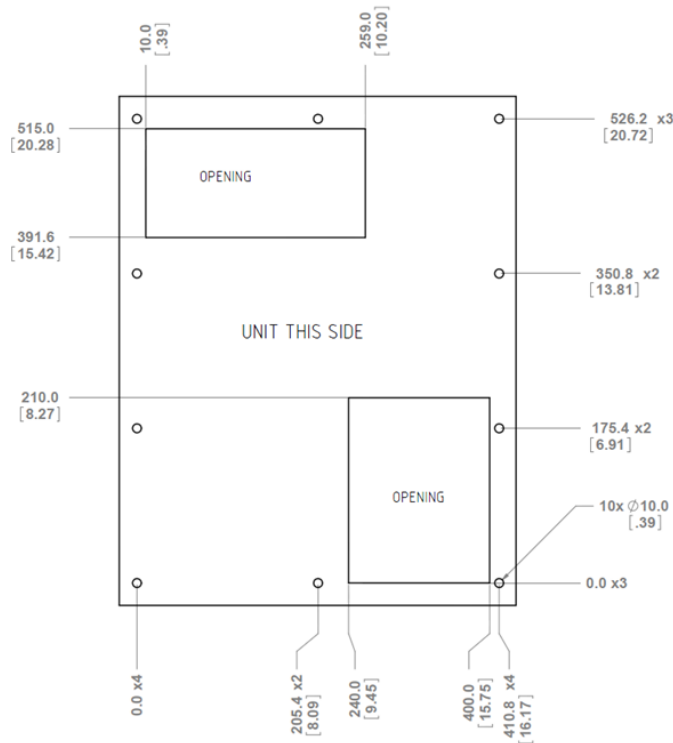

### 5.2.5. Cut Out & Mounting Information PS035XXX-XX series

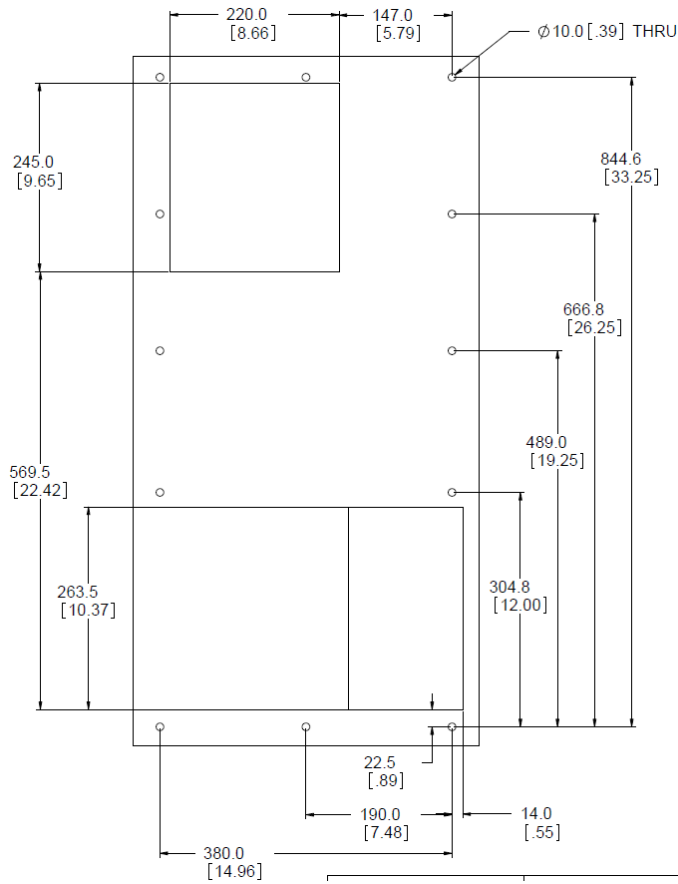

### 5.2.6. Cut Out & Mounting Information PS060XXX-XX series

1. UNLESS OTHERWISE SPECIFIED, ALL DIMENSIONS ARE IN MILLIMETERS
2. MOUNTING TEMPLATE IS DISPLAYED AS MARKED ON MOUNTING SURFACE.
3. CUT AWAY HATCHED AREAS.
4. DO NOT SCALE DRAWING.

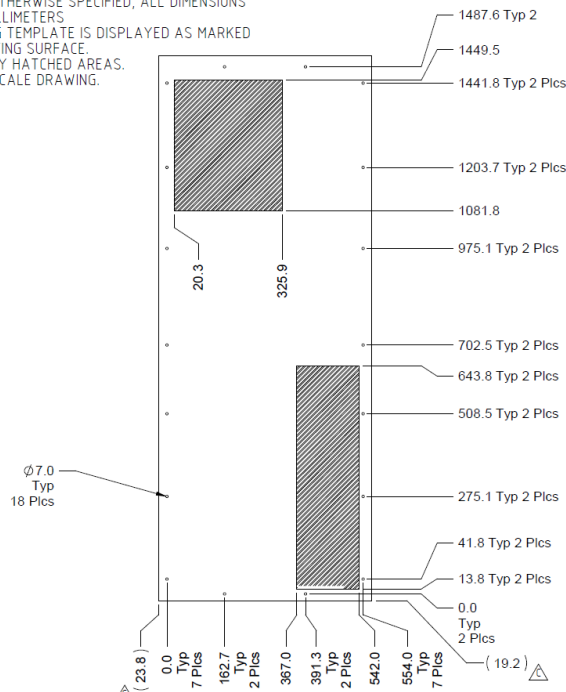



## 6. MOUNTING OF UNIT TO ENCLOSURE & OPERATION

- The enclosure shall be checked for correctness of cutouts, mounting holes and electrical supply.
- The **Mounting Hook** is preset to match the recommended cutout openings. If an adjustment other than the factory setting of the hook needs to be made, do so prior to fixing the gasket to the Heat Exchanger.
- Install the gaskets as shown in section 5.1. A gasket kit is provided with each unit. (Not required for PS018XXX-XX)
- Remove the outer cover of the Heat Exchanger by removing the screws from either the side or bottom of the unit. Depending on options selected, use a #2 Phillips Screwdriver, #20 Torx driver, or #15 Security Torx with pin driver. All screw threads are M4.
- Utilize an appropriate and safe lifting device.
- Mount the Heat Exchanger to the cabinet by using the mounting hook, which supports the weight of the unit. The hook grabs the cut out opening on the cabinet panel.
- Install the mounting hardware as supplied with the unit (M6 x 25 SCKT HD cap screws & washers). The fixings are installed from inside the cabinet into the threaded inserts located in the unit. Use 4mm Allen wrench / driver.
- For PS018XXX-XX:
- Place the unit for the inside of shelter through cutout opening using an appropriate and safe lifting device.
- Connect the Heat Exchanger power lead to the mains supply located in the cabinet/enclosure. **Refer to the product label on the bottom right hand side panel of the unit for the proper voltage/amp requirement. Make sure a properly grounded power supply is used. All installations are to be completed in accordance with local NEC codes and guidelines.**
- The electrical circuit should be protected by a slow blow breaker or fuse. Refer to section 5 in this manual for fuse/breaker rating.
- After final installation and power supply connection the unit should be powered and the unit checked for correct airflow.
- For PS0XX0XX-XX-S (Speed Control)
- Push and hold test button located on control board for 5 seconds, to activate the self test.
- Check to correct airflow and fan speeds.
- Please contact Dantherm for more information if required.

## 7. DESIGN DATA: GENERAL PERFORMANCE

Model #	Watts/°F	Voltage	Hz	Ph	Full load, Amps	Minimum breaker/fuse size, Amps	Approx. Weight (lbs/Kg)
PS018017Y	17	24VDC	N/A	N/A	3.5	4.4	21/9.5
PS018017Z	17	48VDC	N/A	N/A	1.75	2.25	21/9.5
PS023017A	17	115VAC	50/60	1	0.5	0.7	21/9.5
PS023017B	17	230VAC	50/60	1	0.3	0.4	21/9.5
PS023017Y	17	24VDC	N/A	N/A	3.5	4.4	21/9.5
PS023017Z	17	48VDC	N/A	N/A	1.75	2.25	21/9.5
PS023022A	22	115VAC	50/60	1	0.5	0.7	23/10.4
PS023022B	22	230VAC	50/60	1	0.3	0.4	23/10.4
PS023022Y	22	24VDC	N/A	N/A	3.5	4.4	23/10.4
PS023022Z	22	48 VDC	N/A	N/A	1.75	2.25	23/10.4
PS023026Z	26	48VDC	N/A	N/A	1.75	2.25	36/16
PS035035A	35	115VAC	50/60	1	3.4	6	59/27
PS035035B	35	230VAC	50/60	1	0.86	2.5	59/27
PS035035Z	35	48VDC	N/A	N/A	4.3	6	59/27
PS035045A	45	115VAC	50/60	1	3.4	5	64/29
PS035045B	45	230VAC	50/60	1	1.86	2.5	64/29
PS035045Z	45	48VDC	N/A	N/A	4.3	6	60/27
PS035055A	55	115VAC	50/60	1	3.4	5	72/33
PS035055B	55	230VAC	50/60	1	1.86	2.5	72/33
PS035055Y	55	24VDC	N/A	N/A	10.0	12.5	68/31
PS035055Z	55	48VDC	N/A	N/A	4.3	6	68/31
PS060100B	100	230VAC	50/60	1	1	1.5	135/62

\*The information provided above is a general overview for reference only. The customer is responsible for the correct installation and application of each product. As products and features change, the nameplate on the side of the unit should be referred to for correct voltage / current during installation.

## 8. MAINTENANCE

The Heat Exchanger should be examined periodically to determine the required cleaning periods based on the installed environmental conditions. Annual inspections are most typical and will cover the majority of installed locations.

**CAUTION!** Always disconnect power to Heat Exchanger prior to servicing. Scheduled maintenance includes cleaning of fans and Heat Exchanger core as they become contaminated with dust or residue. The fans and Heat Exchanger core should be cleaned using a soft bristle brush to remove dust or debris. Water is NOT recommended. Reconnect power after service.

### 8.1. Wiring Diagrams

The following schematics are of standard products only. Wiring schematics of options or custom products is available directly from Dantherm Air Handling, Inc.

**8.1.1. AC Voltage Diagram: All Models (11/17/22/35/45/55/100) A/B**

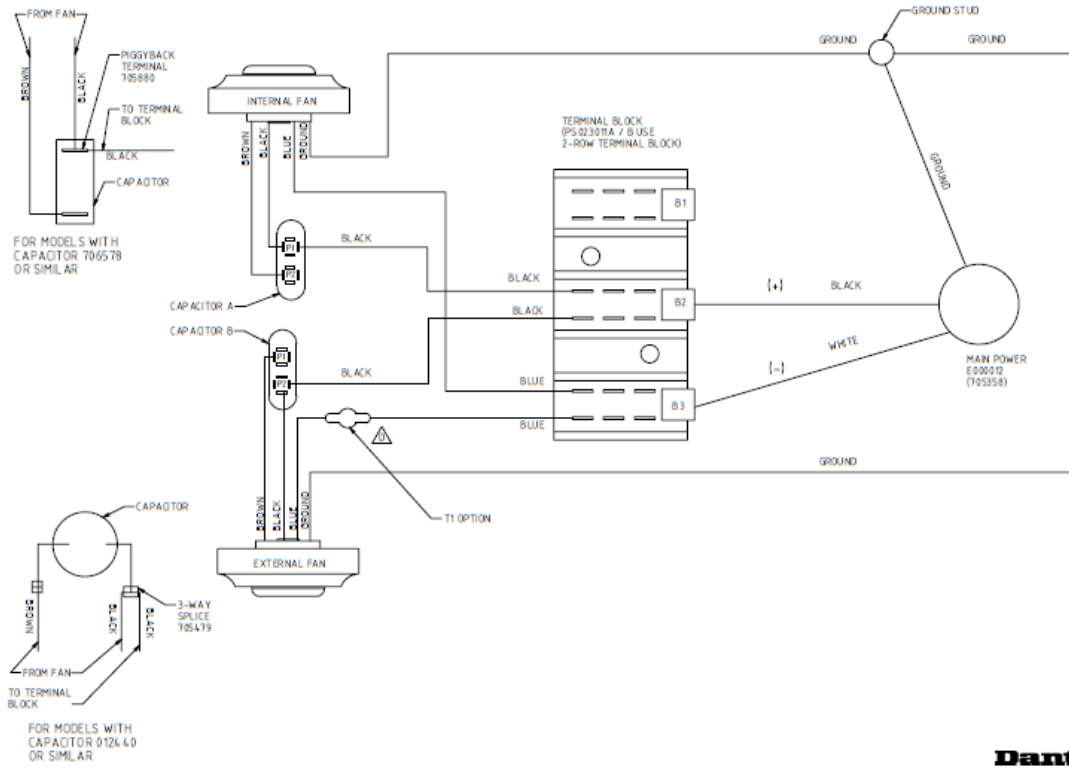

**8.1.2. DC Voltage Diagram: All Models (11/17/22/35/45/55) Y/Z without speed control**

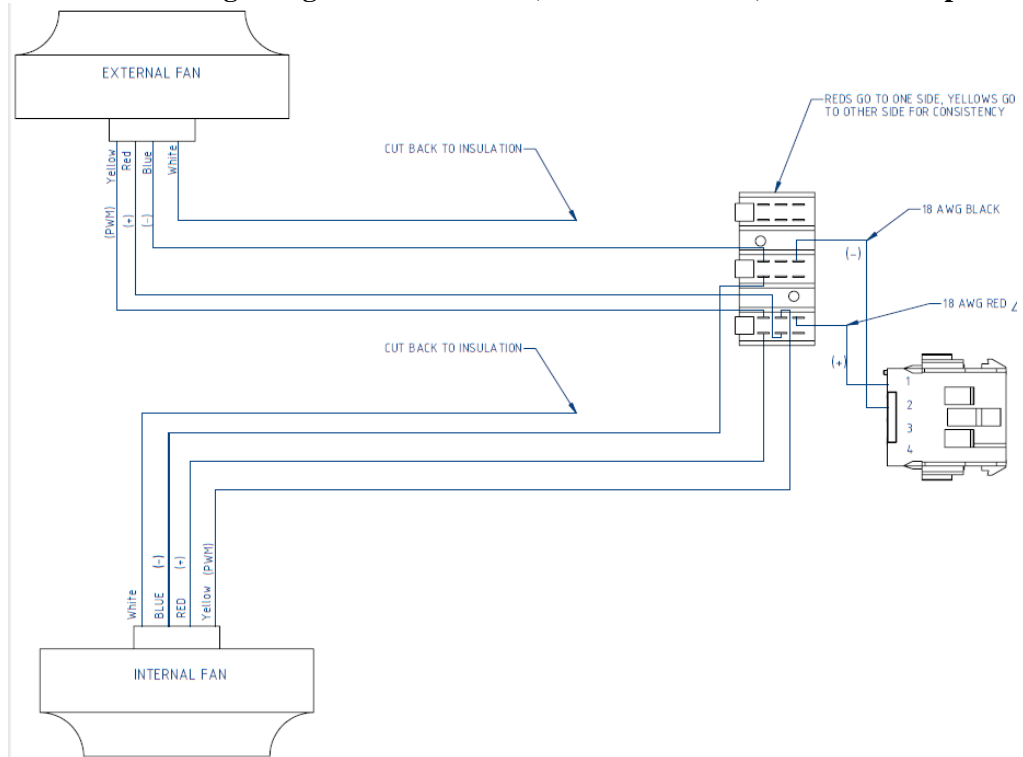

**8.1.3. DC Voltage Diagram: PS0XX0 (11/17/22/35/45/55) Y/Z with HX2 Speed Control**  
(up to batch date 130601)

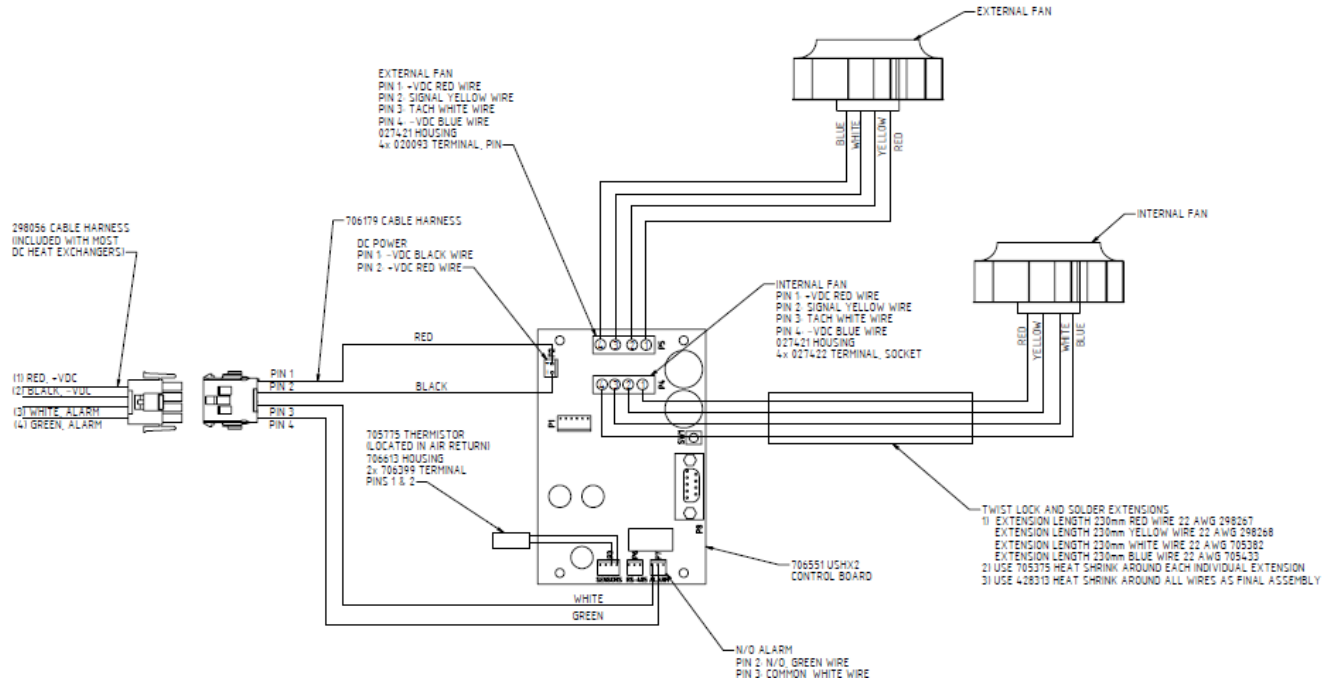

**8.1.4. DC Voltage Diagram: PS0XX0 (11/17/22/35/45/55) Y/Z with HX2 Speed Control**  
(Batch date 130601 and newer)

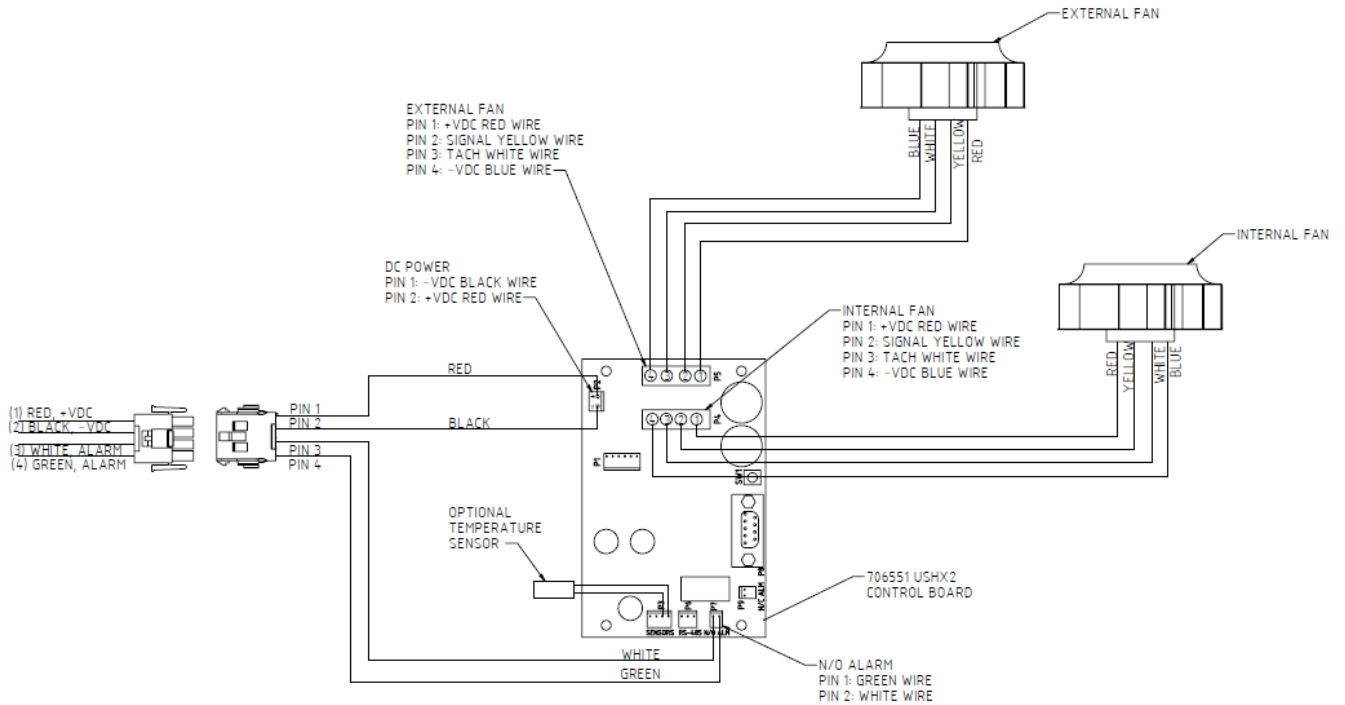

## 9. WARRANTY

### DANTHERM, INC., LIMITED WARRANTY FOR HEAT EXCHANGER AND AIR CONDITIONING UNITS

DANTHERM, INC.'s ("DANTHERM") limited warranty extends to the original purchaser only of any DANTHERM heat exchanger and air conditioning unit, and to no other person or entity. DANTHERM warrants that such DANTHERM products will be free from defects in materials and workmanship in normal use for a period of twelve (12) months from the date of dispatch. Should any part of your DANTHERM product fail because of a manufacturing defect within such twelve (12) month period, DANTHERM terms are set out below:

PRODUCT WARRANTY				SHIPMENT LIABILITY	
PRODUCT	WARRANTY PERIOD*	IN FIELD WARRANTY**	RETURN TO BASE WARRANTY	IN FIELD	RETURN TO BASE
AIR CONDITIONER	12 months	PARTS SUPPLY ONLY	PARTS & LABOR	Supply of item freight pre-paid by Dantherm. Return of defective part pre-paid by customer.	Return of item freight pre-paid by customer. Supply of item freight pre-paid by Dantherm.
HEAT EXCHANGER	12 months	PARTS SUPPLY ONLY	PARTS & LABOR	Supply of item freight pre-paid by Dantherm. Return of defective part pre-paid by customer.	Return freight pre-paid by customer. Supply freight pre-paid by Dantherm.

\*\* Using Dantherm nominated service contractors – warranty on product continues  
 Using Dantherm non-approved service contractors – warranty on product becomes void

Warranty period starts from shipment date – warranty of replacement parts shall only apply for the remainder of the warranty period of the original product.

*Any transportation, related service labor, diagnosis calls, filters, driers, and refrigerant are not included. In the event all related service labor is performed by DANTHERM nominated service contractors, the replacement part shall be warranted by DANTHERM for the remainder of the warranty period of the original product.*

This warranty does not cover damages or repairs caused by improper installation, misuse of the product, negligent servicing, improper applications, unauthorized modifications, improper electrical supply, failure to follow manufacturer's instructions and rating plate information, accidents, natural disasters, damage in transportation, lack of normal preventive maintenance, or other events beyond DANTHERM's control. This warranty is also subject to the following operating conditions: 1) voltage variation not greater than 10%, 2) frequency variation not greater than 3Hz from nameplate rating, 3) cooling load is not greater than product label under rated conditions 4) unit is not restarted for a period of five minutes after accidental or intentional shut-off, 5) operation is not subject to abnormal conditions or customer, user misapplication, 6) customer or user does not modify, abuse, or neglect the product, 7) refrigerant specified on nameplate is only refrigerant used, and 8) customer or user complies with all other installation, maintenance, and operating instructions. Cost of repair or replacement of consumable parts is not covered under the terms of this warranty.

**THIS WARRANTY CONSTITUTES THE EXCLUSIVE REMEDY OF ANY PURCHASER OF A DANTHERM PINNACLE HEAT EXCHANGER AND CLASSIC AIR CONDITIONING UNIT AND IS IN LIEU OF ALL OTHER WARRANTIES, EXPRESS OR IMPLIED, INCLUDING, WITHOUT LIMITATION, ANY IMPLIED WARRANTIES OF MERCHANTABILITY, FITNESS FOR USE, OR FOR A PARTICULAR PURPOSE. IN NO EVENT SHALL ANY IMPLIED WARRANTIES OF MERCHANTABILITY, FITNESS FOR USE, OR FOR A PARTICULAR PURPOSE EXCEED THE TERMS OF THE APPLICABLE WARRANTY STATED ABOVE, AND DANTHERM SHALL HAVE NO OTHER OBLIGATION OR LIABILITY, EXPRESS OR IMPLIED. IN NO EVENT SHALL DANTHERM BE LIABLE FOR ANY INCIDENTAL OR CONSEQUENTIAL DAMAGES.**

**THIS WARRANTY GIVES YOU SPECIFIC LEGAL RIGHTS, AND YOU MAY ALSO HAVE OTHER RIGHTS WHICH VARY FROM STATE TO STATE. SOME STATES DO NOT ALLOW LIMITATIONS OR EXCLUSIONS, SO THE ABOVE LIMITATIONS AND EXCLUSIONS MAY NOT APPLY TO YOU.**

## **10. RETURN MATERIAL AUTHORIZATION PROCEDURE**

In the unlikely event of unit failure the following return procedure shall be adopted.

All product returns require a Return Material Authorization number regardless of reason.

The customer is required to contact the Quality Department at Dantherm, Inc. in Spartanburg, SC at +1 864 595 9800 to obtain an RMA number.

The following information must be provided prior to a RMA number being issued:

- Dantherm, Inc. part number(s) of product to be returned.
- Dantherm, Inc. serial number(s) of product to be returned.
- Number of units requested to be returned.
- Reason for return.
- Contact name, phone and fax number.
- Date of product receipt.
- Invoice number and purchase order number covering the unit(s).

The customer is responsible for suitably packaging the unit(s) securely, ideally in the original packaging, marking all cartons with the RMA number and shipping them prepaid to the designated site specified by Dantherm, Inc.

**IN NO EVENT SHALL DANTHERM, INC. ACCEPT ANY SHIPMENT WHICH DOES NOT COMPLY WITH THE ABOVE PROCEDURES.**

**REMOVE THE EMERGENCY HOSE AND ADAPTER FROM THE BOTTOM OF THE UNITS PRIOR TO DISMANTLING THE AIR CONDITIONER AND RESTING IT ON THE GROUND.**